

**PITAGONE** anti-ram vehicle barriers are designed, developed and produced in Belgium





The **PITAGONE F18** was tested in its fully operational position

• **FUNCTIONAL MOBILITY SYSTEM** •

Observation after each Crash-Test: **Engine destroyed | Vehicle Disabled**

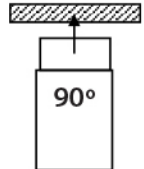

Head-on attack

   <b>FUNCTIONAL MOBILITY SYSTEM</b>			
Test Designation	Vehicle Mass	Test Speed	Test Angle
N3/N3C	7.5-18T 	48 km/h	90° 



Offset attack

Tested by the German authorities  <b>FUNCTIONAL MOBILITY SYSTEM</b>		
Test Designation	Vehicle Mass	Test Speed
N3/N3C CP1S	12T 	42 km/h

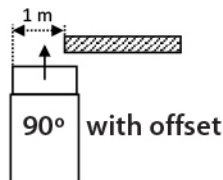
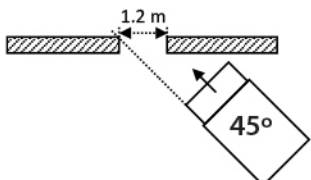

Side-on attack (45°)

Test angle	
 90° with offset	 45°

**ADVANTAGES:**

- 1 • Unique, mobile solution against ram vehicles.
- 2 • Tested with functional mobile system.
- 3 • Ultra-fast assembly, does not require any tools.
- 4 • Easy storage and transport (Rack and SecurityBox).
- 5 • Long life cycle, minimal maintenance.
- 6 • Model does not cause panic.
- 7 • Energy and lateral shock absorption.
- 8 • Adjustable to two widths.
- 9 • Easy assembly by one person.

**RAPID ASSEMBLY**



**COLOUR/BRANDING CUSTOMISATION**





### SPECIFICATIONS :

- Height **100 cm**
- Width **9 cm**
- Depth **104 cm**
- Total weight **38,5 Kg**

### Distance between the modules:

- Liaison bars in position 25 **43,5 cm**
- Liaison bars in position 50 **68 cm**

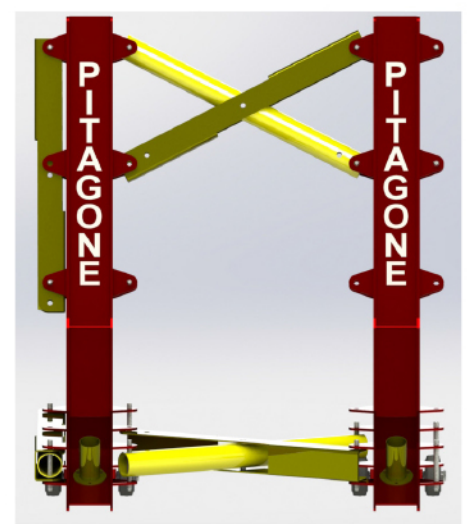
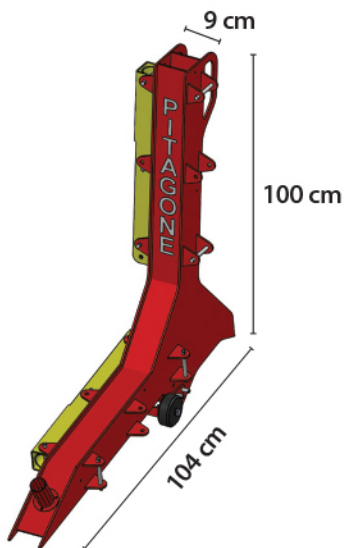

### RACK F18

- Resistant to the harshest usage conditions.
- An operational productivity time-saver.
- More efficient use of space in your warehouses.
- Significant reduction in transport costs.
- Quick and easy to handle.
- Prevents: theft, breakage and loss.
- Dimensions : 137 cm x 108 cm x 120 cm
- Net weight : 95 kg / Weight with 6 modules : 326 kg

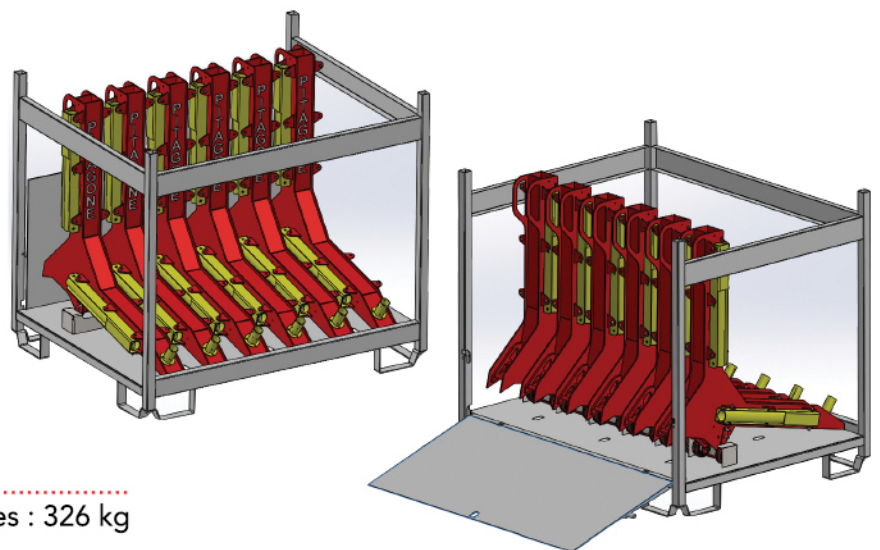

## PITAGONE Sa-Nv

Paepsem Boulevard, 16  
1070 Brussels | Belgium

Tel: +32 2 896 63 33 - Fax: +32 2 896 63 34  
info@pitagone.com VAT: BE 0659 697 790

Order in  
multiples of 6

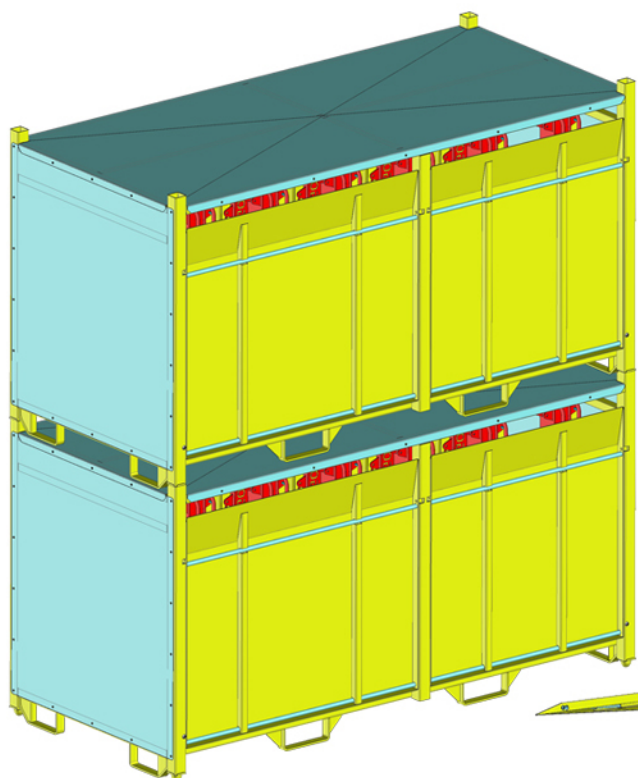

## THE CONTAINER BEST SUITED TO THE STORAGE AND TRANSPORT OF YOUR F18

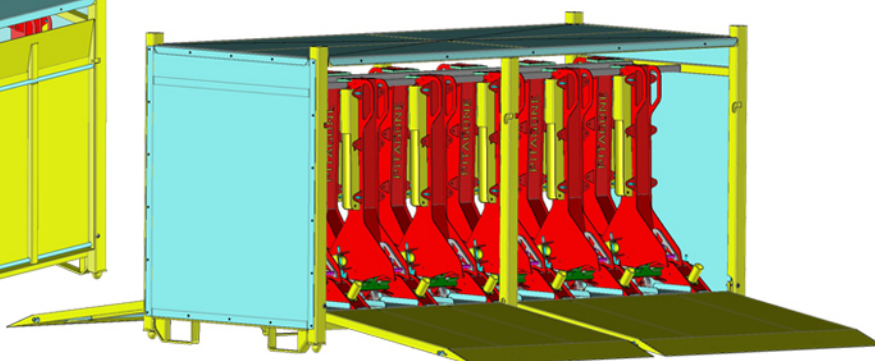

### CONTAINER DIMENSIONS

• Length	<b>2,5 m</b>
• Width	<b>1,2 m</b>
• Height	<b>1,35 m</b>
• Net weight	<b>415 kg</b>
• Weight with 12 modules	<b>877 kg</b>

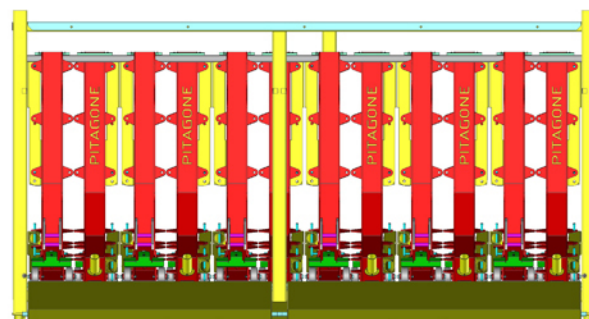

- Allows better use of space in your warehouses and a significant reduction in transport costs.
- Quick and easy to handle.
- Galvanised steel chassis.
- These containers can be customised with the name of your company.
- Protect F18 from weather disruptions and avoid theft, breakage and loss.

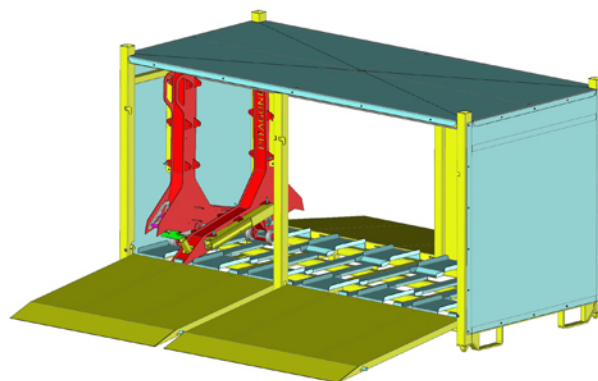

## THE OPERATIONAL SOLUTION FOR YOUR PITAGONE BARRIERS

### PITAGONE Sa-Nv

Paepsem Boulevard, 16  
1070 Brussels | Belgium

Tel: +32 2 896 63 33 - Fax: +32 2 896 63 34  
info@pitagone.com VAT: BE 0659 697 790